



FINISHED GOODS PRODUCT SPECIFICATION

Item: 7190806 Rosemary Croccantini, FS, Minis 12/8oz (6lb)

Customer: Everyday

Season: Everyday

Year: 2013

PRODUCT PHOTO



PRODUCT INFORMATION

Product Weight / Volume: 8.0 oz

Units per Case: 12

UPC: 6-59000-40109-8

GTIN: 1-06-59000-40109-5

Case UPC: NA

Product Size: 12" x 4.417" x 2.125"

Case Size (OD): 13.5625" x 12.3125" x 9.125"

Case Weight (NET): 6.0 lbs

Case Weight (TOTAL): 8.0 lbs

CRACKER INFORMATION

Width: 1.6 inches +/-0.5

Length: 3.4 inches +/-0.15

SHIPPING INFORMATION

Case Pack Size: 13.5625" x 12.3125" x 9.125"

Units per Case: 12

TI HI Pallet (48" max height): 9 x 4

Cases per 48" Pallet: 36

TI HI Pallet (96" max height): 9 x 9

Cases Per 96" Pallet: 81

Cases Per Floor Loaded Container: N/A

Units Per Floor Loaded Container: N/A

Pallet Net Weight (96" plt): 486 lbs

Pallet Gross Weight (96" plt): 703 lbs

CASE PACK PHOTO



LABELING INFORMATION

Country: USA / Canada (on Cases Only)

Language: English / French (on Cases Only)

Label Approval Required (Y/N): Y (on cases) N (on units)

Nutritional Info Format: USA / Canada (on Cases Only)

Price Label (Y/N): N

PALLET CONFIGURATION

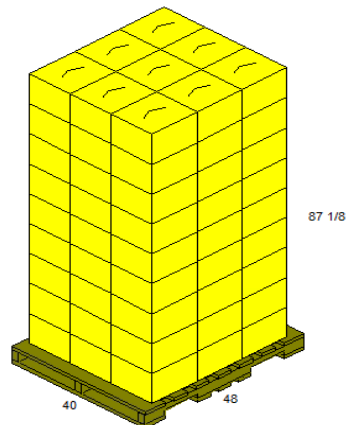

SHELF LIFE

Guaranteed Shelf Life: 5 Months

Total Product Shelf Life: 208 Days

OPTIMAL STORAGE CONDITIONS

Temp for storage: 65-80 degrees

Suitable for Freezing (Y/N): N

COMPLIANCE INFORMATION

SPECIAL INSTRUCTIONS

Date code should be in this format on side of container:

Example: Flavor: Rosemary
Best By DD MMM YY shift: 07 DEC 13 C
Meilleur avant YY MM DD: 13 DE 07
Product of USA

