



FINISHED GOODS PRODUCT SPECIFICATION

Item: 7110806 Original Croccantini, FS, Minis 12/8oz (6lb)

Customer	Everyday
Season	Everyday
Year	2013

PRODUCT PHOTO



PRODUCT INFORMATION	
Product Weight / Volume	8.0 oz
Units per Case	12
UPC	6-59000-40110-4
GTIN	1-06-59000-40110-1
Case UPC	NA
Product Size	12" x 4.417" x 2.125"
Case Size (OD)	13.5625" x 12.3125" x 9.125"
Case Weight (NET)	6.0 lbs
Case Weight (TOTAL)	8.0 lbs

CRACKER INFORMATION	
Width	1.6 inches +/- .05
Length	3.4 inches +/- .15

SHIPPING INFORMATION

CASE PACK PHOTO

Case Pack Size	13.5625" x 12.3125" x 9.125"
Units per Case	12
TI HI Pallet (48" max height)	9 x 4
Cases per 48" Pallet	36
TI HI Pallet (96" max height)	9 x 9
Cases Per 96" Pallet	81
Cases Per Floor Loaded Container	N/A
Units Per Floor Loaded Container	N/A
Pallet Net Weight (96" plt)	486 lbs
Pallet Gross Weight (96" plt)	703 lbs



LABELING INFORMATION	
Country	USA / Canada
Language	English / French
Label Approval Required (Y/N)	Y (on cases) N (on units)
Nutritional Info Format	USA / Canada (on Cases)
Price Label (Y/N)	N

PALLET CONFIGURATION

SHELF LIFE	
Guaranteed Shelf Life	5 Months
Total Product Shelf Life	208 Days

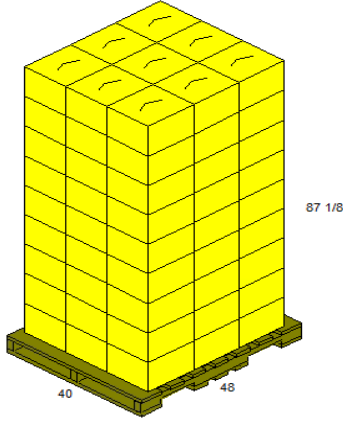

OPTIMAL STORAGE CONDITIONS	
Temp for storage	65-80 degrees
Suitable for Freezing (Y/N)	N

COMPLIANCE INFORMATION

SPECIAL INSTRUCTIONS

Date code should be in this format on side of container:

Example:

Flavor

Best By DD MMM YY shift

Meilleur avant YY MM DD

Product of USA

1515 1221731

Original

Best by 07 DEC 13 C

Meilleur avant 13 DE 07

Product of USA

1515 1221731